

## AIRPORT GROUND LIGHTING CONTROL (AGLC)

### COMPLIANCES

**ICAO:** Annex 14 - Volume I, Aerodrome Design Manual Part 5, Manual of Surface Movement Guidance and Control System DOC 9476-AN/927, Advanced Surface Movement Guidance and Control Systems (A-SMGCS) Manual DOC 9830-AN/452

**FAA:** L-890T AC150/5345---56A

**NATO:** STANAG 3316

**IEC:** 62143-61508

AGLC represents the software application package proposed by AC DEFENSE as the Airport Lighting Control and Monitoring System. AGL allows to manage from regional through international hubs airports, thanks to its modular and scalable design.

### OVERALL KEY---FEATURES

- ICAO and FAA compliant for operation up to CAT III
- Easy to use and first glance-oriented HMIs
- SLMCS (Single Lamp Control and Monitoring System) oriented for preventive airport light maintenance, increasing safety and reliability
- Power line based SLCMS for cost-cutting cabling and easy extension
- Stop bar Lights Control
- Runway Safety Area Management and Runway Incursion detection
- Stop Bar Lights and RSAMS Controllers available on separate dedicated HMIs
  - easy interfacing with ILS, RVR, AWOS and Power Supply on site existing equipment, showing processed data on dedicated Category HMI
  - Robust server - server or server - client or client - server redundant architecture
  - Easy interfacing with third parties
  - Easy features' tuning for small and medium sized airports' requirements
  - Easy and safe reconfiguration of HMI
  - Flexible and customized software
  - Tower HMI supervision by remote

### GENERAL OVERVIEW

AGL software package:

- is installed on Windows---based workstations, located in Control Tower and in one or more other places (power stations and maintenance center)
- is mainly based on a dedicated LAN Ethernet network backbone
- primarily uses the communication protocol Echelon Lon works, the ANSI/CEA EIA709.1 international standard, due to its performances and robustness so to ensure maximum stability and safety
- controls and monitors all the airfield units (CCRs and other users) through network microcontrollers, in order to achieve the full management of airport lighting operative functionalities, making AGLC a true and reliable DCS (Distributed Control System).

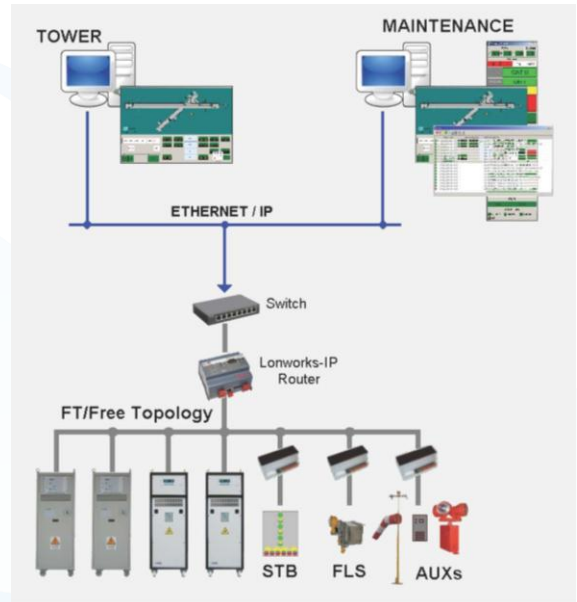

## BASIC CONTROL APPLICATION

- AGLC Console is the main AC DEFENSE ALCMS application with an intuitive GUI/HMI that:
- Shows the current status of the complete airfield lighting system, as located on the airport map
- Shows the current status of all CCRs and all other users, highlighting specific alarms
- Allows to forward commands only if the master ship is acquired, by tower or maintenance operators; only one station a time can hold the command master ship to control CCRs and other units
- Manages pre-set commands, as per visibility mode (day, twilight, night), runway visual range and category of operations (CAT)
- Allows to command CCRs in "single mode" or "group mode", as circuits are grouped for functionalities and redundancies;
- Shows a different layout, tailored for Control and Maintenance operators.

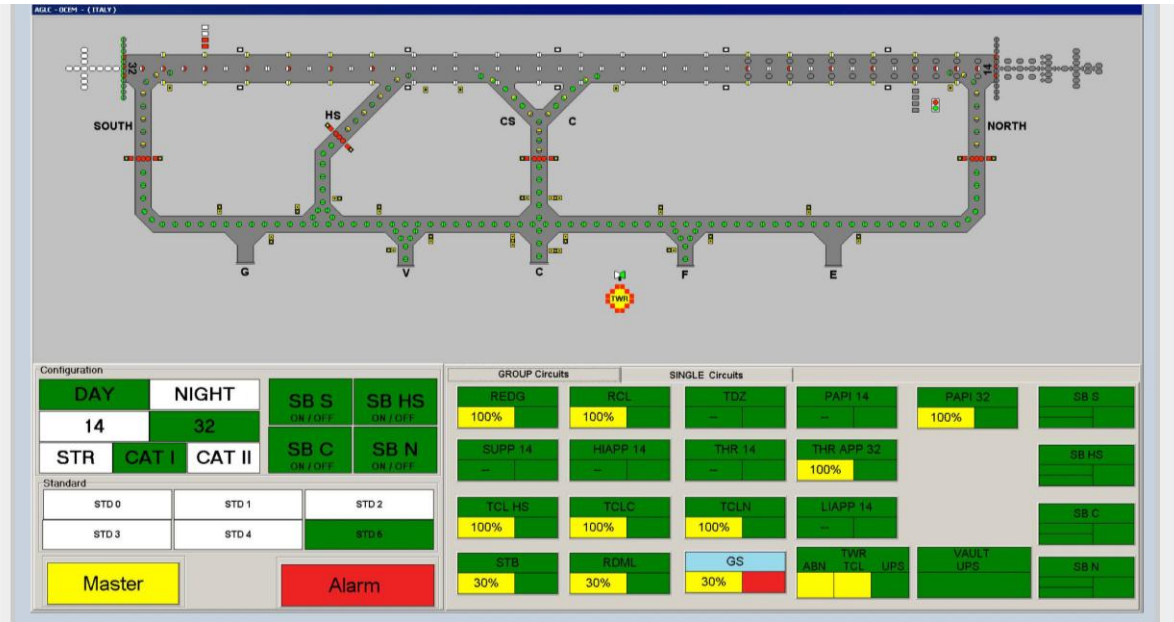

## ADDITIONAL OPERATIONAL AND MAINTENANCE APPLICATIONS

AGLC Console can integrate and show additional applications depending on the airport operational needs.

- **Stop Bar Control (SBC)**--ATC operators can independently manage (switch-off) each stop bar; the following automated activation can be via timer or, preferably, by field transit sensors
- **Category Console (CC)** – this application interfaces ILS/RVR/AWOS and Power Supply equipment providing the ATC operators the current and forecast operational category
- **Runway Safety Area Management System (RSAMS)**-- this application allows ATC operators to supervise the ground traffic and to control the runway entrances by field transit sensors, when the airfield lighting system is not used
- **Single Lamp Control Monitoring System (SLCMS)** – Maintenance personnel can steadily monitor the status of each single lamp through dedicated pop---up window

- **Insulation Resistance Monitoring System (IRMS)** – Maintenance personnel can steadily monitor the insulation level of the series cables of each circuit
- **Logger** --- it logs all airfield lighting events and alarms, allowing deeply analysis filtering stored data
- **Net Monitor** --- it monitors the status of Ethernet connections

## STOP BAR CONTROL (SBC)

- This application, **which can be also integrated with the SLCMS**, allows ATC operators to independently manage and monitor the stop bars with the associated lead on paths located at the runway taxiway intersections, by dedicated pushbuttons provided on the AGLC console
- The pushbutton operation opens a specific pop-up window which allows the ATC operators to monitor the lamp and sensor status, send the "GO command", follow the aircraft transit through the intersection, be immediately alerted in case of runway incursion detection or other alarm conditions

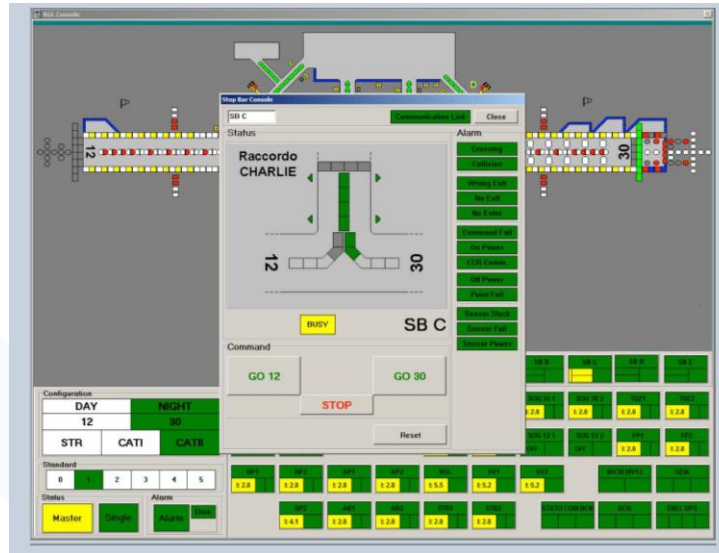

Typical Control Tower HMI – Stop bar management pop---up window

- SBC can be supplied as a stand-alone application too, running on a separate workstation or on a separate touchpad small computer depending on the complexity of the stop bar system



Typical Stop bar Touchpad

## **CATEGORY CONSOLE (CC)**

- This application interfaces ILS/RVR/AWOS and Power Supply equipment, processes the relevant data and integrates them with Airfield Lighting status, in order to provide the current operational category
- Moreover, it informs the operators about the forecast operational category and suggests how to set the Airfield Lighting through the AGLC application.
- On request the Airfield Lighting setting can be automated.

## **RUNWAY SAFETY AREA MANAGEMENT SYSTEM (RSAMS)**

- RSAMS is an independent application which integrates and manages the information coming from the "runway safety ring" realized by the field traffic sensors located at all holding positions
- RSAMS monitors the aircraft and vehicle movements at the runway/taxiway intersections in order to detect unauthorized runway entries (Runway Incursions) and unauthorized exits from runway (Wrong Maneuvers)
- Each violation is notified to the operators through an immediate acoustic and visual alarm. The system can also command the eventual traffic lights installed at the road/runway intersections to provide a visual runway entry authorization to the maintenance drivers
- RSAMS can be supplied as a stand---alone application too, running on a separate workstation or on a separate touchpad small computer depending on the complexity of the stop bar system
- RSAMS is completely integrated with the SBC, when provided



## FIELD TRANSIT SENSOR SYSTEM (FTSS)

- Microwave and magnetic loop sensors located at the runway/taxiway intersections and along the taxiing routes are used to detect the presence of aircrafts and vehicles
- Their information is collected inside control cabinets which communicate with the AGLC using fibre optic loops for immediate availability
- Sensors and cabinets take power by dedicated or stop bar/taxiway series circuits.

## SINGLE LAMP CONTROL MONITORING SYSTEM (SLCMS)

SLCMS, designed with the focus on a high level of operating performance/safety and for a simple handling/installation, is performed by specific equipment using the series circuit cable for data transmission:

- Addressable units (MCC), each monitoring one or two lamps
- Central Units (ECB), each monitoring and controlling all the lamps belonging to a series circuit supplied by a CCR.

MCCs are easily field installable between fittings and isolation transformers thanks to FAA connectors, ECBs are coupled to the series circuits inside the substations and communicate to the AGLC through the CCRs.

SLCMS package:

- shows through dedicated windows specific runway/taxiway zones with an accurate lamp layout;
- reports the current status of each single lamp and addressable unit.
- SLCMS can be integrated with SBC for stop bar management

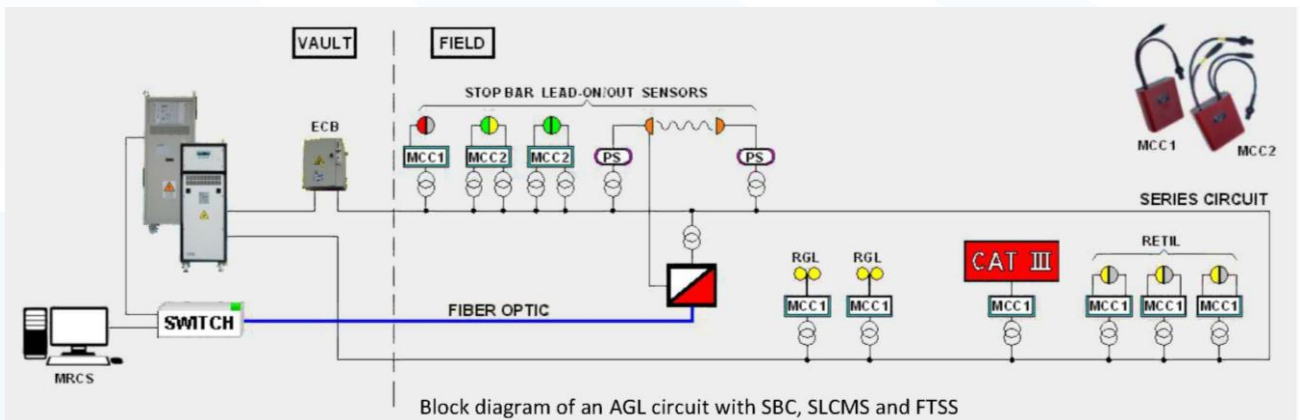
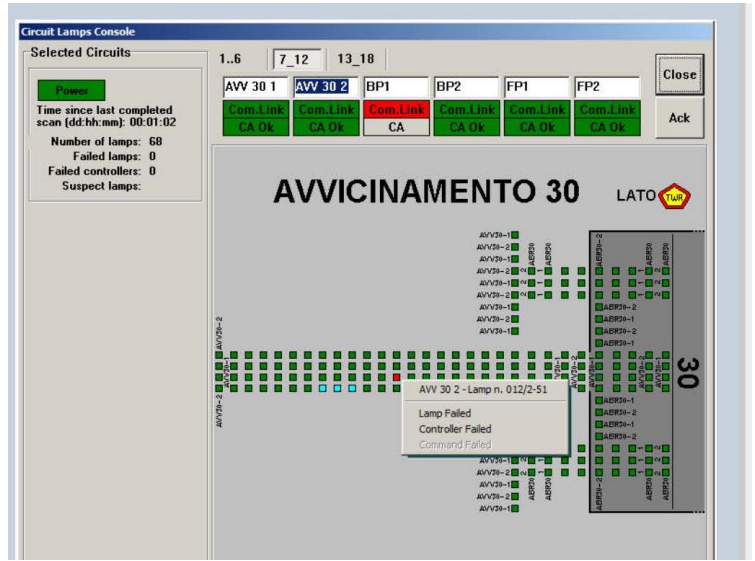

## INSULATION RESISTANCE MONITORING SYSTEM (IRMS)

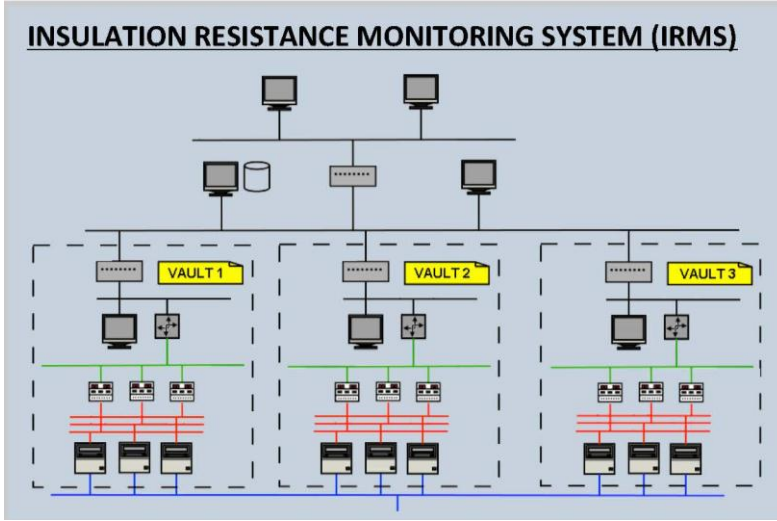

IRMS application collects the information provided by IRM units, automatic devices that performs periodic insulation resistance tests on the airfield lighting series circuits

IRMS application permits to inform in real time the maintenance personnel about the actual insulation resistance value and any warning or alarm conditions, and shows the insulation resistance trend in a graphic format, allowing preventive maintenance actions

IRMS application is an independent package which can be integrated in AGLC.

## LOGGER

This logging application comes with the AGLC basic package:

- logs all airport light related events and alarms, unit states and commands
- stores trace historian in a specific database
- is usually located on the maintenance station
- is supplied to analyze subsequently traces stored
- allows custom filtering to highlight traces per unit types, per data types (states, alarms, commands) and per time periods.

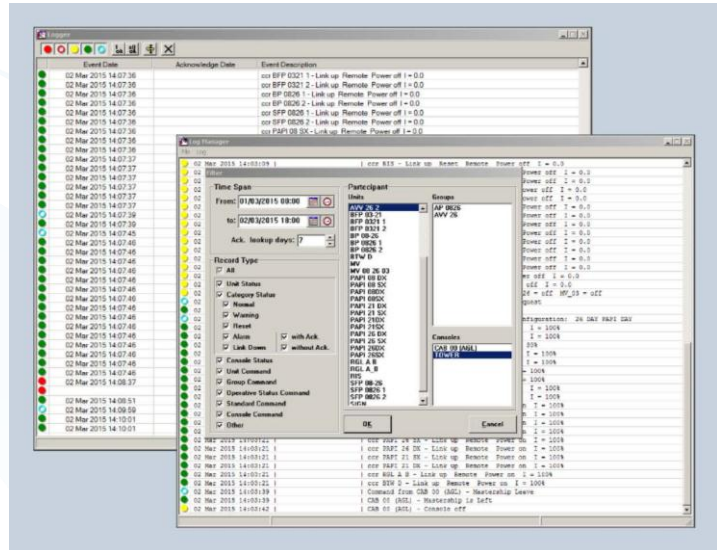



## **NET MONITOR**

The Net Monitor application is supplied mainly where fiber optics links are present:

- it monitors the states of Ethernet connections, as reported by special switches used
- its shows on the HMIs the faulted links, in order to facilitate maintenance operations;
- it interfaces with Logger application to update the system historian for Ethernet link.

